

NOTES:

1. THE "T" & "E" DIAMETERS ARE THE AVERAGE OF 2 MEASUREMENTS TAKEN APPROXIMATELY 90° APART
2. THE "T" DIAMETER IS TAKEN TOWARD THE BOTTOM OF THE CLOSURE JUST BELOW THE START OF FULL THREAD
3. THE "E" DIAMETER IS TAKEN AS CLOSE TO THE INSIDE DECK AS POSSIBLE
4. THE EFFECTIVE "H" DIMENSION CAN BE ESTIMATED BY SUBTRACTING .028 FROM THE SPECIFIED "H" DIMENSION. THIS REFLECTS THE ESTIMATED COMPRESSION OF THE SEALING MECHANISM AT NOMINAL APPLICATION TORQUE

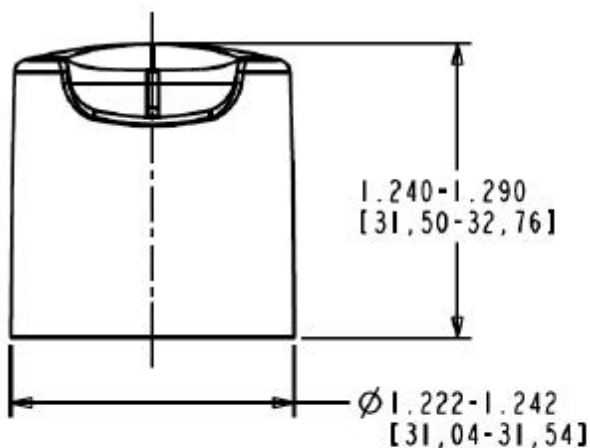

RECOMMENDED NECK FINISH

LAND MUST BE SMOOTH AND FREE OF NICKS OR RAGGED EDGES
6 T.P.I. - "M" STYLE THREAD
USE OF BEAD IS OPTIONAL
TWO THREAD TURNS STANDARD
THREE THREAD TURNS OPTIONAL

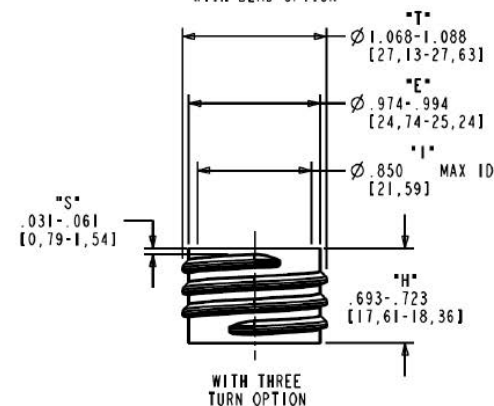
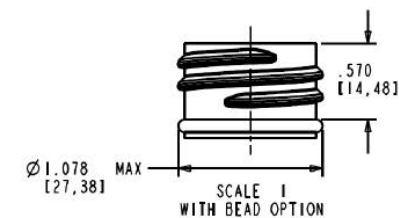

NOMINAL ORIFICE SIZES AVAILABLE

	.170 X .430 [4,32 X 10,92]
	.170 X .330 [4,32 X 8,38]

DISCLAIMER

THIS INFORMATION IS PROVIDED AS A GENERAL GUIDE, INCLUDING DIMENSIONS. IT IS THE CUSTOMER'S RESPONSIBILITIES TO SELECT THE PROPER CONTAINER FOR PRODUCT AND APPLICATION COMPATIBILITY.

DISTRIBUTED BY:



REF NO.:

DESCRIPTION: