

Per C.M.A. Standard
 "T" = 1.103/1.089 Dia.
 "E" = 1.009/0.995 Dia.

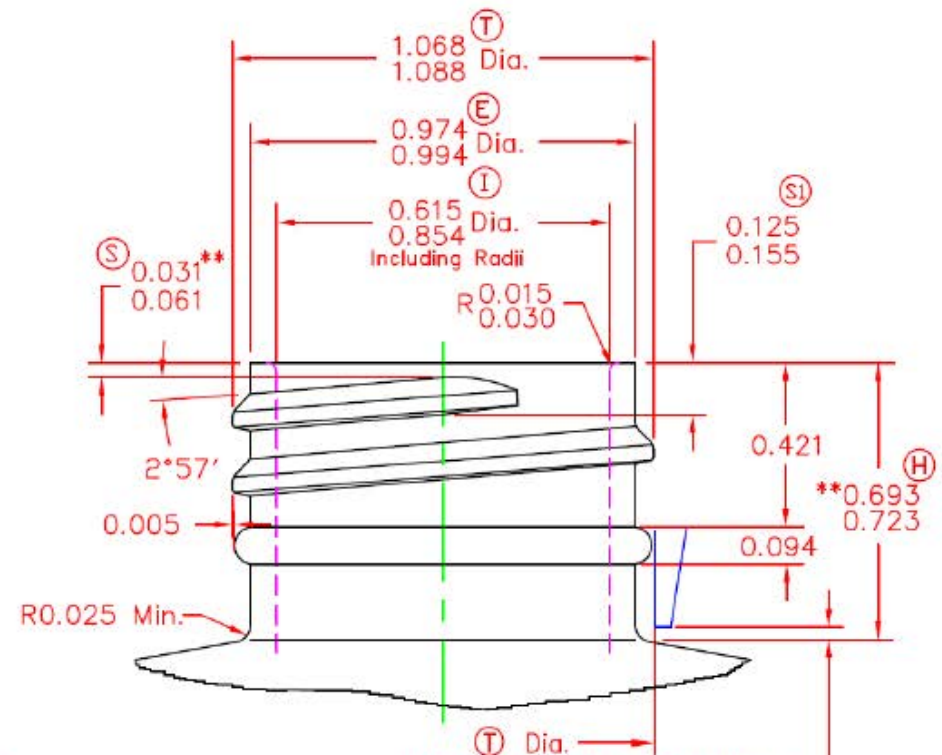

** Bottle "H" Dim. Creates a
 Cap Skirt-Bottle Shoulder
 Clearance Of .015" To .061"
 This can be adjusted to Suit
 Aesthetic Requirements
 (Min. Functional "H" .678")

BOTTLE NOTES:

- 1) Thread: 6 Pitch, Per S.P.I. Standard.
- 2) Diameters must be concentric within .015" T.I.R.
- 3) All Dimensions are in inches unless otherwise indicated.

Ⓔ

Dimensions marked * are an average of two measurements taken 90° apart.
 GENERAL TOLERANCE NOT SHOWN OTHERWISE: ± .008

DISCLAIMER

THIS INFORMATION IS PROVIDED AS A GENERAL GUIDE, INCLUDING DIMENSIONS. IT IS THE CUSTOMER'S RESPONSIBILITIES TO SELECT THE PROPER CONTAINER FOR PRODUCT AND APPLICATION COMPATIBILITY.

DISTRIBUTED BY:



REF NO.:

DESCRIPTION: