

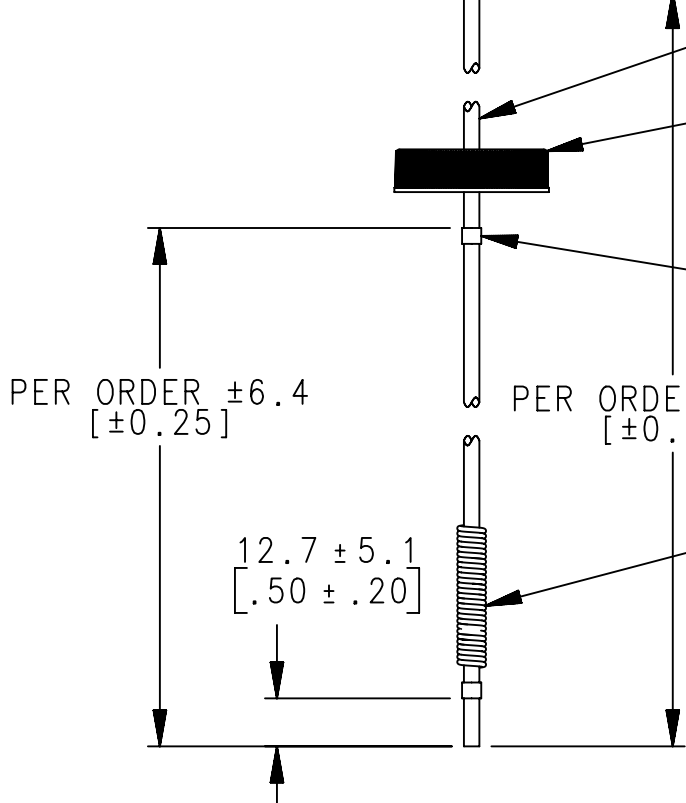

MIXOR TRIGGER SPRAYER
 1.3CC OR 1.6CC OUTPUT PER STROKE
 BALL VALVE: CELCON
 SPRING: STAINLESS STEEL
 VALVE BODY: POLYPROPYLENE
 PISTON: POLYETHYLENE
 SHELL: POLYPROPYLENE
 NOZZLE: POLYETHYLENE
 TRIGGER: POLYPROPYLENE
 SPIN MECHANICS: POLYETHYLENE



TUBING
 PVC
 CLOSURE (38-400 UNLINED)
 POLYPROPYLENE
 RETAINER (CRIMP) (2X)
 MATERIAL: AMALLOY
 WEIGHT: STAINLESS STEEL

DISTRIBUTED BY: 	REF NO.: DWG30839
DESCRIPTION: 38-400 White PP Trigger Sprayer, 12.7" Dip Tube	

DISCLAIMER
 THIS INFORMATION IS PROVIDED AS A GENERAL GUIDE, INCLUDING DIMENSIONS. IT IS THE CUSTOMER'S RESPONSIBILITIES TO SELECT THE PROPER CONTAINER FOR PRODUCT AND APPLICATION COMPATIBILITY.