

GENERAL INFORMATION

- Product group: Caps or Seals
- Type model: Tools are available for manual - pneumatic and fully automatic application in filling lines
- Material: Galvanized plate
- Size: G2 (50mm) Cap
- Surface print / Finish: No Print
- Washer: No washer

PACKAGING INFORMATION

- Component weight (grams): 14
- Box quantity (pieces): 500
- Box weight (kg): 7

Material: Galvanized/Plate std.
Finish: No Print

COMMENTS

- More information about application can be found on our website under "Library of brochures". Please contact your local Tri-Sure® Sales representative for packaging advice and testing for specific products.
- For the correct application of our products general information is available on our website www.Tri-Sure.com.
- The raw materials used are in compliance with US CONEG §37.0205 and EEC Directive 94/62/EC of 13-12-94 on Packaging waste (<100ppm for Heavy Metal content)
- PRIVATE design Tri-Sure® Tab-Seal® Cap printed with customer logo, printable area is Ø 54mm for G2 and Ø 26mm G¾ caps
- STANDARD design Tri-Sure® Tab-Seal® Cap
- Minimum order quantity: Sets = 15.000; G2 = 18.000; G¾ = 62.500
- Manual and pneumatic crimp-on tools are available, please contact your local Tri-Sure® sales and support centre
- Flowed-in gasket is from solid or foamed PVC based plastisol
- All EU metal Tab-Seal® caps are improved for enhanced sealability and easier removal

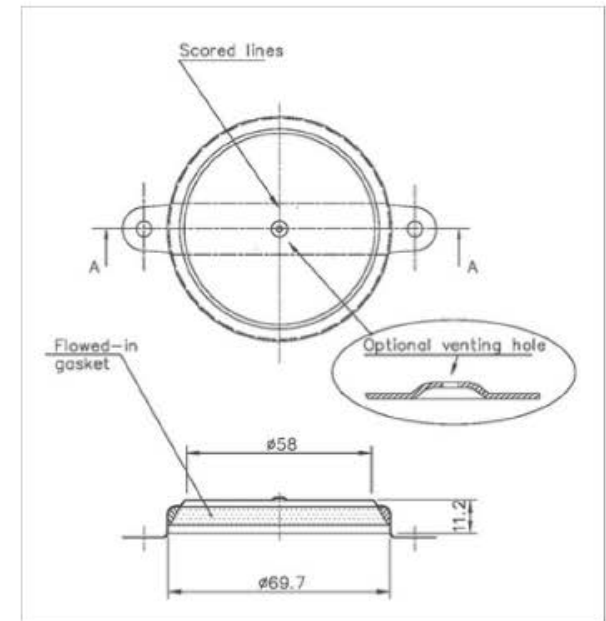

DISCLAIMER

THIS INFORMATION IS PROVIDED AS A GENERAL GUIDE, INCLUDING DIMENSIONS. IT IS THE CUSTOMER'S RESPONSIBILITIES TO SELECT THE PROPER CONTAINER FOR PRODUCT AND APPLICATION COMPATIBILITY.

DISTRIBUTED BY:



REF NO.:

DESCRIPTION: