

SHOULD
DETAIL
SCALE 10:1

BOTTOM PLATE LETTERING TO BE .156 [3.97] TALL
EXCEPT CAVITY NUMBER TO BE .188 [4.76] TALL.

C.I.D. RINGS TO APPEAR ON BOTTOM.

BPK-160 TO APPEAR ON BEARING SURFACE.

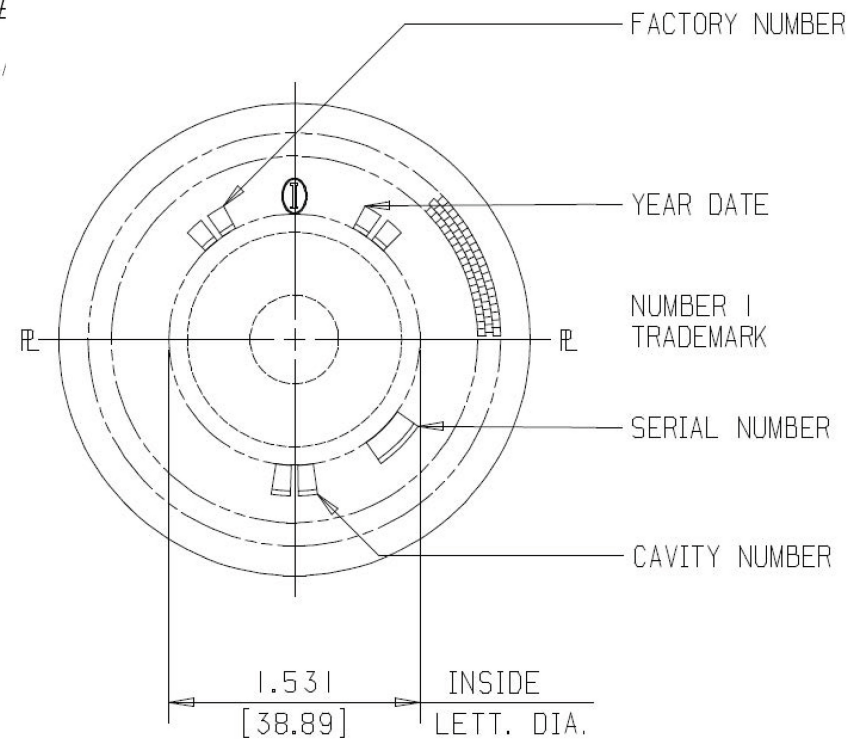

DISCLAIMER

THIS INFORMATION IS PROVIDED AS A GENERAL GUIDE, INCLUDING DIMENSIONS. IT IS THE CUSTOMER'S RESPONSIBILITIES TO SELECT THE PROPER CONTAINER FOR PRODUCT AND APPLICATION COMPATIBILITY.

DISTRIBUTED BY:



DWG NO.:

DWG20017

DESCRIPTION:

9 oz Flint Straight Side Jar, 70-400