

SECTION A-A

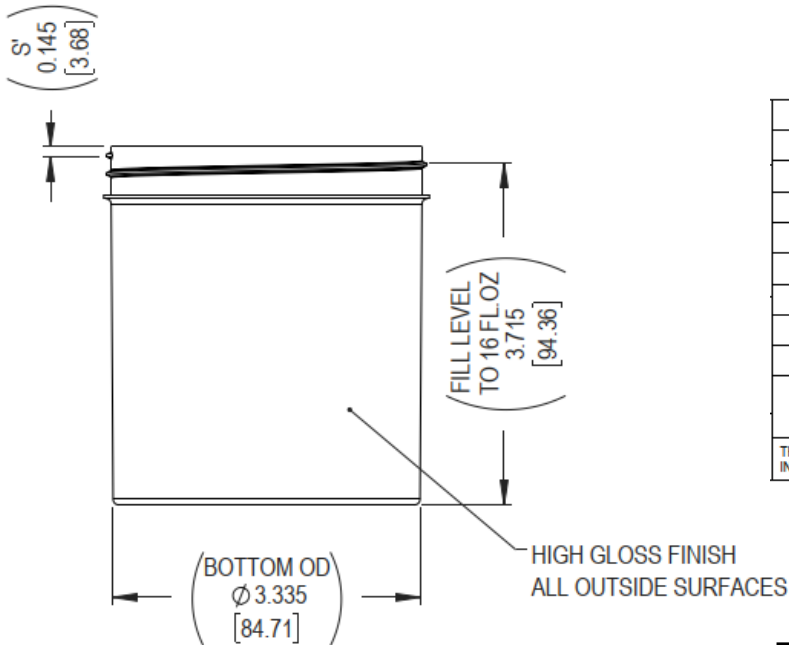

REFERENCE	DIMENSION	TOLERANCE	UNITS
$\varnothing T$	3.486 [88.54]	$\pm 0.010 [0.25]$	in [mm]
$\varnothing E$	3.375 [85.73]	$\pm 0.010 [0.25]$	in [mm]
$\varnothing I$	3.245 [82.42]	$\pm 0.010 [0.25]$	in [mm]
H	0.525 [13.34]	$\pm 0.010 [0.25]$	in [mm]
OAH	3.895 [98.93]	$\pm 0.010 [0.25]$	in [mm]
OD	3.540 [89.92]	$\pm 0.010 [0.25]$	in [mm]
PART WEIGHT	51.00	$\pm 4.00$	g
VOLUME	16.69 [493.6]	REFERENCE	fl oz [cc]
THREAD DETAIL INFORMATION:	5 THREADS PER INCH	0.200" [5.08] PITCH	450+ FULL DEPTH THREADS

DISTRIBUTED BY:



REF NO.:

DWG30963

DESCRIPTION:

16 oz Clear PS Straight Side Jar, 89-400

**DISCLAIMER**

THIS INFORMATION IS PROVIDED AS A GENERAL GUIDE, INCLUDING DIMENSIONS. IT IS THE CUSTOMER'S RESPONSIBILITIES TO SELECT THE PROPER CONTAINER FOR PRODUCT AND APPLICATION COMPATIBILITY.