

KNURLS
(.008 DEEP)

NOTES:

1. .040 LINER SHOWN
2. DIAMETERS TO BE TAKEN AS AVERAGE
3. THREAD PROFILE: MODIFIED BUTTRESS
4. REFERENCE Q1M-500-A105 FOR NECK FINISH REQUIREMENTS
5. RECOMMENDED 48 HOUR-REMOVAL TORQUE: 8-12 IN. LBS
6. MAT'L: POLYPRO

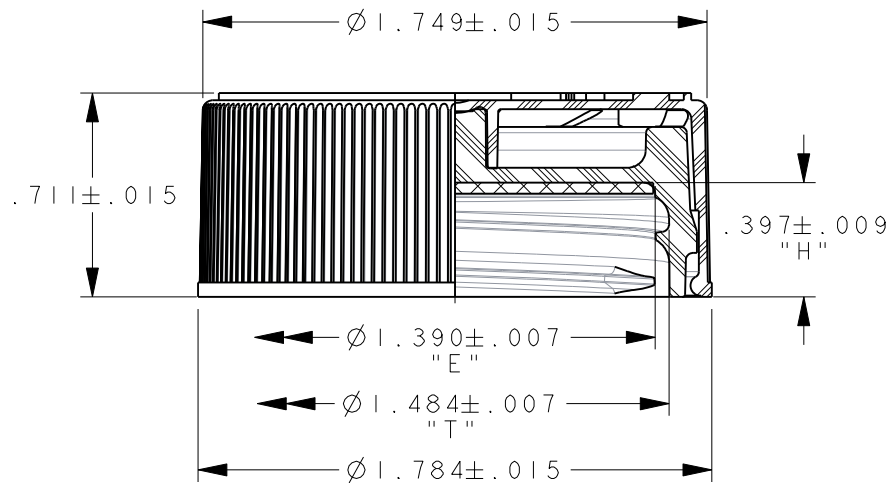

DISCLAIMER

THIS INFORMATION IS PROVIDED AS A GENERAL GUIDE, INCLUDING DIMENSIONS. IT IS THE CUSTOMER'S RESPONSIBILITIES TO SELECT THE PROPER CONTAINER FOR PRODUCT AND APPLICATION COMPATIBILITY.

DISTRIBUTED BY:



REF NO.:

DWG30871

DESCRIPTION:

38-400 White PP Plastic Child Resistant Cap, Push Down & Turn, .035 M1 Heat Seal for PE