

Container Specification

Entity Code	Entity Description	Value	Tolerance	Text
	Nominal Fill Volume	500 ml		
	Container Gross Lidded Capacity	550 ml		
	Container Weight	90 g		
	Body Material Specification	0.20 mm TS275		
	Top End Material Specification	0.29 mm TS275		
	Bottom End Material Specification	0.28 mm TS275		
	Size and Style Code	S00410		
HE	Overall Container Height	166.00 mm		
H	Body Height Over Seams	154.00 mm		
AA	Body Internal Length	96.00 mm		
AB	Body Internal Width	42.00 mm		
ACA	Bottom Seam External Length	98.00 mm		
ACB	Bottom Seam External Width	44.00 mm		
NH	Screw Neck Depth	15.08 mm		
SDI	Screw Aperture Internal Diameter	17.40 mm	+05/-00	
DTM	Screw Thread Root Diameter	23.90 mm	+00/-025	
DTO	Screw Thread Crest Diameter	25.32 mm	+00/-025	
TP	Screw Thread Pitch	3.175 mm		

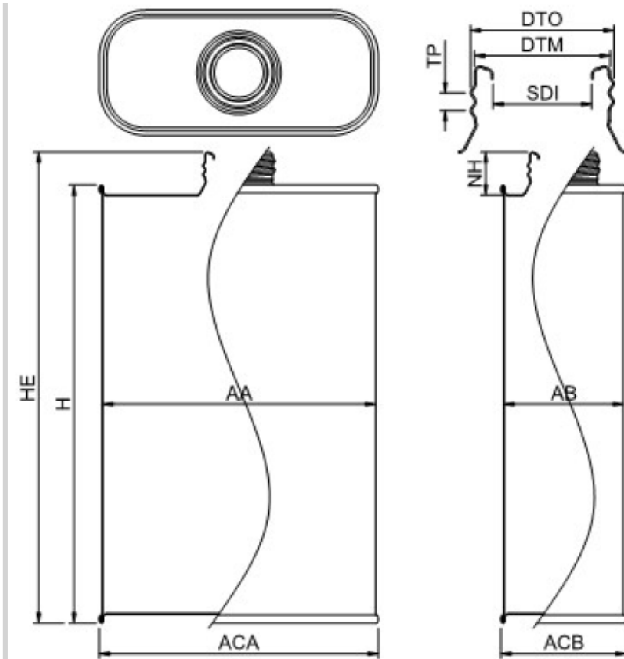

Print Area

Entity Code	Entity Description	Value	Tolerance	Text
BL	Body Blank Length	250.90 mm		
BH	Body Blank Height	157.15 mm		
BP	Blank Print Length	245.30 mm		
PM	Blank Print Margin	2.80 mm		
PF	Blank Textless Print Width	1.50 mm		
PW	Blank Detail Print Length	242.30 mm		
HW	Blank Detail Print Margin	4.30 mm		
PH	Blank Detail Print Height	147.15 mm		
PK	Blank Detail Print Top Margin	5.00 mm		
PL	Blank Detail Print Bottom Margin	5.00 mm		
PP	Blank Front Panel Width	66.14 mm		
PN	Blank Back Panel Width	66.14 mm		
PS	Blank Side Panel Width	11.81 mm		
PR	Blank Corner Panel Width	23.57 mm		
PT	Blank Corner Panel Minor Part Width	4.62 mm		
PU	Blank Corner Panel Part Width	14.07 mm		

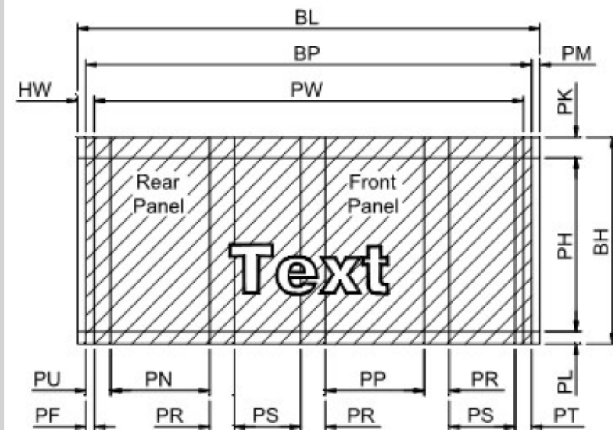

DISCLAIMER

THIS INFORMATION IS PROVIDED AS A GENERAL GUIDE, INCLUDING DIMENSIONS. IT IS THE CUSTOMER'S RESPONSIBILITIES TO SELECT THE PROPER CONTAINER FOR PRODUCT AND APPLICATION COMPATIBILITY.

DISTRIBUTED BY:



REF NO.:

DWG10190

DESCRIPTION:

500ml Rectangular Container 096x042x154mm - Straight Wall with Integral 25mm Screw Neck_Sp