

# Product Specifications

## 3.5-Gallon Round Screw-Top Pail with Screw-Top Cover, Closed Handle Version

Note: \*Rated for Solids Y16/S for Packaging Group II and III (USA and Canada)

### Multiple Uses

Dry Products  
UN Solids rated to Y16/S

### Product Codes

Container:  
Description: 3.5 Gallon 85 MIL Quarter Turn Screw-Top Pail

Cover:  
Description: Gasketless, Quarter Turn, Screw-Top Cover

### Features

Gauge: 85 mil.  
Nominal capacity: 3.5 USG / 13.25 L  
Stack performance: 350lbs.\*  
Tare weights: Body: 1.52 lbs. / .69 kgs.  
Tare weights: Cover: .66 lbs. / .30 kgs.  
Note: \* Ratings will be reduced with uneven load distribution.

### Specifications with Cover

Dimensions: 12-5/16" DIA. X 11-3/32"H  
Maximum capacity: 3.87 USG / 14.67 L  
Tare weight: 2.18 lbs. / .99 kgs.

### Colors

Standard: White, Black, Natural  
Custom: Available at manufacturer's discretion

### Decorating Options\*

Note: \*See Decoration Summary for further details.

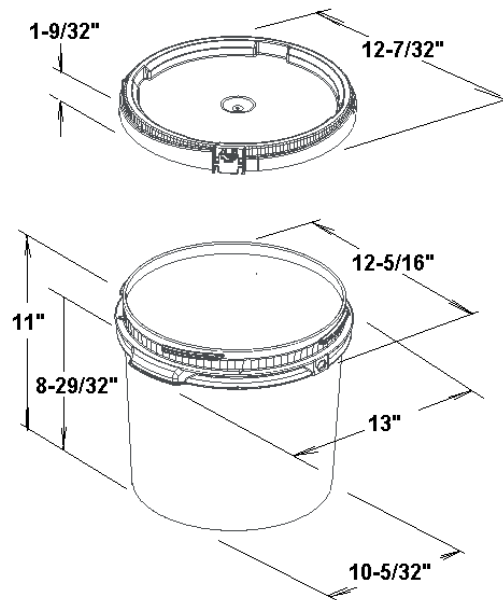

### Shipping Data

	<u>Bodies</u>	<u>Covers</u>
Qty. per pallet:	228	480
Gross Weight (lbs./kgs.):*	346.56/157.32	317.5/144
Den. (lbs./C.F./kgs./m3):	6.6/105.56	6.44/103.15
Length (in./cm.):	49.88/126.7	49/124.46
Width (in./cm.):	37.56/95.6	36.75/93.35
Height (in./cm.):	48.44/123.04	47.31/120.2

Estimated truckload quantity of 8,200 bodies and 8,640 covers\*\*

Notes: \*Weight does not include pallet / packaging  
\*\*Truckload quantity based on 53' trailer

### Filled Containers

48 (12 per layer / 4 layers high)  
Pallet height: 47.61"

### Materials

FDA and HPB approved materials Resin:  
Body: High Density Polyethylene (HDPE)  
Cover: High Density Polyethylene (HDPE)  
MSDS Sheets available upon request

### Optional Carrying Handle

Plastic

DISTRIBUTED BY:



REF NO.:

DWG31018

DESCRIPTION:

3.5-Gallon White HDPE Screw Top Pail with Plastic Handle

### DISCLAIMER

THIS INFORMATION IS PROVIDED AS A GENERAL GUIDE, INCLUDING DIMENSIONS. IT IS THE CUSTOMER'S RESPONSIBILITIES TO SELECT THE PROPER CONTAINER FOR PRODUCT AND APPLICATION COMPATIBILITY.