

Features

Gauge: 90 mil.

Nominal capacity: 6.5 USG / 24.6 L

Stack performance: 350lbs.*

Tare weights: Body: 2.54 lbs. / 1.15 kgs.

Tare weights: Cover: .66 lbs. / .30 kgs.

Note: * Ratings will be reduced with uneven load distribution.

Specifications with Cover

Dimensions: 12-5/16" DIA. X 18 7/8" H

Maximum capacity: 6.78 USG / 25.67 L

Tare weight: 3.20 lbs. / 1.45 kgs.

Colors

Standard: White, Black, Natural

Custom: Available at manufacturer's discretion

Decorating Options*

Note: *See Decoration Summary for further details.

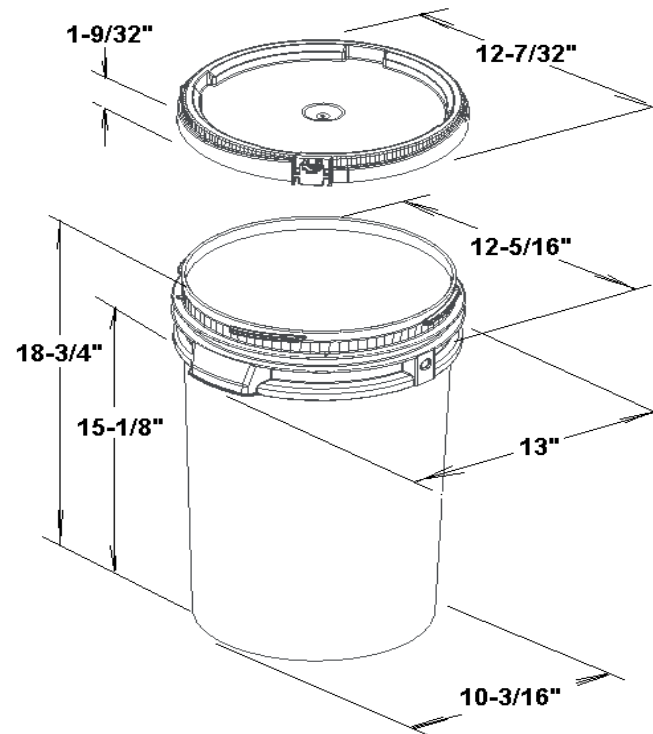

Shipping Data

Qty. per pallet:
 Gross Weight (lbs./kgs.):*
 Den. (lbs./C.F./kgs./m3):
 Length (in./cm.):
 Width (in./cm.):
 Height (in./cm.):

Bodies

108
 274.32/124.2
 5.3/84.58
 49.88/126.7
 37.56/95.6
 47.75/121.3

Covers

480
 317.5/144
 6.44/103.15
 49/124.46
 36.75/93.35
 47.31/120.2

Filled Containers

36 (12 per layer / 3 layers high)
 Pallet height: 60.52"

Materials

FDA and HPB approved materials Resin:
 Body: High Density Polyethylene (HDPE)
 Cover: High Density Polyethylene (HDPE)
 MSDS Sheets available upon request

DISCLAIMER

THIS INFORMATION IS PROVIDED AS A GENERAL GUIDE, INCLUDING DIMENSIONS. IT IS THE CUSTOMER'S RESPONSIBILITIES TO SELECT THE PROPER CONTAINER FOR PRODUCT AND APPLICATION COMPATIBILITY.

DISTRIBUTED BY:



REF NO.:

DWG30262

DESCRIPTION:

6.5 Gallon White HDPE Screw Top Pail