

## Features

UN Rating: 3H1/Y1.8/100  
Nominal capacity: 5.3 USG / 20.0L  
Maximum capacity: 5.65 USG / 21.4 L  
Tare weights: 2.73 lbs / 1.24 kgs

## Colors

Standard: White, Black, Blue and Natural  
Custom: Available at manufacturer's discretion

## Decorating Options

Maximum Label Area:  
Perimeter: 38-1/4" x 8-11/16" H  
See Salesperson for Options

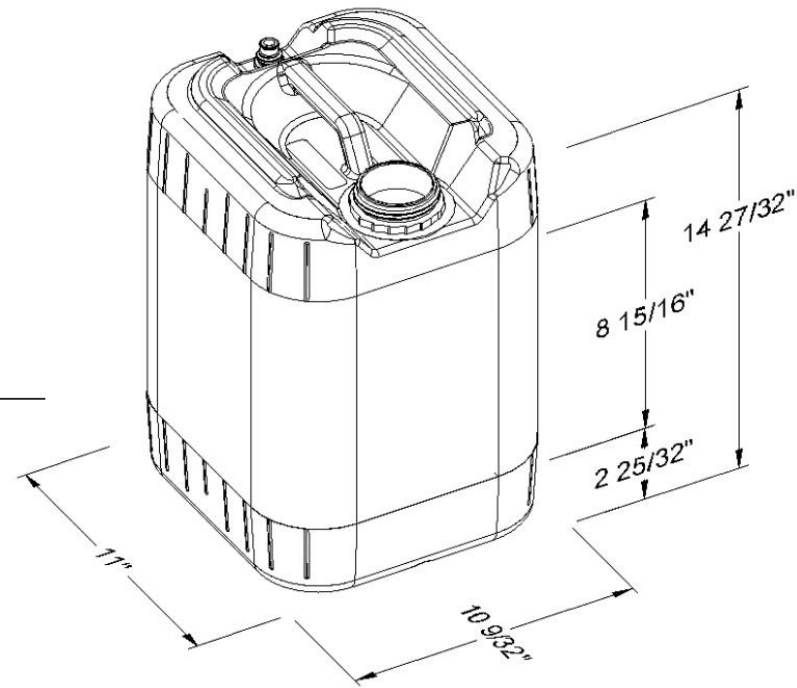

## Shipping Data

Qty. per floor spot:	112
Gross Weight (lbs./kgs)*:	306 / 139
Length (in./cm.):	44 / 112
Width (in./cm.):	33 / 84
Height (in./cm.):	107 / 273

## Containers

Estimated truckload quantity of 3,360 containers\*\*

Notes: \*Weight does not include pallet / packaging  
\*\*Truckload quantity based on 53' trailer

## Materials

FDA approved materials  
Resin: Body: High-Density Polyethylene (HDPE)

## Optional Carrying Handle

Integral

### DISCLAIMER

THIS INFORMATION IS PROVIDED AS A GENERAL GUIDE, INCLUDING DIMENSIONS. IT IS THE CUSTOMER'S RESPONSIBILITIES TO SELECT THE PROPER CONTAINER FOR PRODUCT AND APPLICATION COMPATIBILITY.

DISTRIBUTED BY:



REF NO.:



DWG30406

DESCRIPTION:

20 Liter Natural HDPE Square TH Pail with Integrated Handle

REV. & DATE: A - DAY 4/7/2022

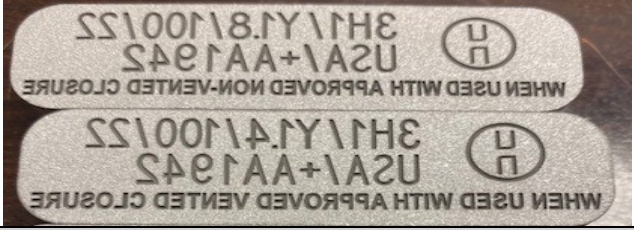
APPROVED BY:

<b>PART SPECS</b>				
<b>SIZE:</b>	20 Liter	<b>NECK FINISH:</b>	70 MM, 6 TPI ,TE Screw Cap	
<b>WEIGHT:</b>	1275g +/- 25g	<b>PHOTO:</b>	Photo may not be representative of actual color	
<b>VENT FINISH:</b>	Closed Vent 21 MM, TE			
<b>RESIN:</b>	0610205, Chevron 50100, VIRGIN 10 MI			
<b>COLOR:</b>	Natural			
<b>ADDITIVE:</b>	NA			
<b>FOOD GRADE:</b>	Yes			
<b>UN TAGS:</b>	3H1/Y1.8/100/XX/USA/+AA1942 and Y1.4			
<b>CAP INSTRUCTIONS</b>				
<b>DUST CAP/CAP:</b>	0910051, DUST CAP 70MM - NPC	<b>VENT CAP/PLUG:</b>	0911943 White TE Vent Cap 21 MM	
Face the dustcover tabs toward the handle, Torque Vent Cap to 30 in-lbs				
<b>SLEEVES/LABELS:</b>	NA	NA		
<b>PACKING INSTRUCTIONS</b>				
<b>TRAYS:</b>	0711172, CORR TRAY SST TH 46 X 41	<b>STRETCH WRAP:</b>		YES, 1510115
<b>PIECES PER BUNDLE:</b>	112	<b>BANDING:</b>	3 x 4 Banding Straps, 1510154	
<b>PALLET:</b>	1410123 - 48 x 40 #1 4 Way			
<b>PALLET TAG/LABELS:</b>	One pallet label per tray.			

**SPECIAL INSTRUCTIONS / CUSTOMER SPECIFIC PHOTOS**

All spouts must face each other, not exposed to outside of pallet.

Sidewalls must be flat. No spots of contamination larger than a pencil point (•) allowed. MAX 5 pencil-point size spots. No loose particulate, debris or grease allowed on the outside or inside of the container

<p align="center"><b><u>DISCLAIMER</u></b></p> <p>THIS INFORMATION IS PROVIDED AS A GENERAL GUIDE, INCLUDING DIMENSIONS. IT IS THE CUSTOMER'S RESPONSIBILITIES TO SELECT THE PROPER CONTAINER FOR PRODUCT AND APPLICATION COMPATIBILITY.</p>	<p>DISTRIBUTED BY: </p>	<p>REF NO.: DWG30406</p>
	<p>DESCRIPTION: 20 Liter Natural HDPE Square TH Pail with Integrated Handle</p>	