

20.0 Liter Square Tight Head with Integrated Handle

Product Uses

Liquid Products

Product Codes

Container: **STH Series**

Description: 20L Square Tighthead

Features

UN Rating: 3H1/Y1.8/100

Nominal capacity: 5.3 USG / 20.0L

Maximum capacity: 5.65 USG / 21.4 L

Tare weights: 2.73 lbs / 1.24 kgs

Colors

Standard: White, Black, Blue and Natural

Custom: Available at manufacturer's discretion

Decorating Options

Maximum Label Area:

Perimeter: 38-1/4" x 8-11/16" H

See Salesperson for Options

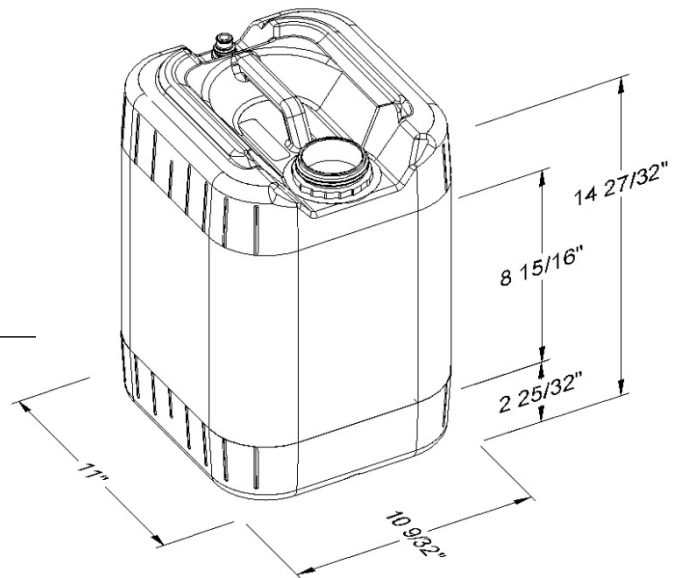

Shipping Data

Qty. per floor spot:

Containers

112

Gross Weight (lbs./kgs)*:

306 / 139

Length (in./cm.):

44 / 112

Width (in./cm.):

33 / 84

Height (in./cm.):

107 / 273

Estimated truckload quantity of 3,360 containers**

Notes: *Weight does not include pallet / packaging

**Truckload quantity based on 53' trailer

Materials

FDA approved materials

Resin: Body: High-Density Polyethylene (HDPE)

Optional Carrying Handle

Integral

DISTRIBUTED BY:



REF NO.:

DWG30628

DISCLAIMER
THIS INFORMATION IS PROVIDED AS A GENERAL GUIDE, INCLUDING DIMENSIONS. IT IS THE CUSTOMER'S RESPONSIBILITIES TO SELECT THE PROPER CONTAINER FOR PRODUCT AND APPLICATION COMPATIBILITY.

DESCRIPTION: 20 Liter White HDPE Plastic Square Tight Head Pail, 70 mm, Closed Vent Stem, 6TPI