

G-TAINER

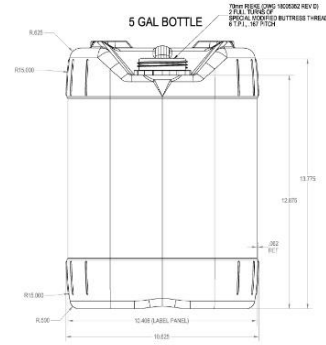
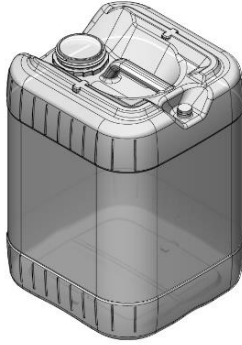

Applications

Industrial chemicals, agricultural chemicals, coatings, adhesives, flavorings, janitorial and sanitation, vehicle care, and other applications.

Styles

Integrated or internal buttress options available.

Closures

- Tamper-evident screw caps
- Solid screw caps

Vent Options

- Plain back (no vent stem)
- Closed vent

Neck Sizes

70mm (6 tpi)

Special Features

- All container sizes and neck finishes meet UN 3H1 standards
- Tight-head containers can be made with 100% high density polyethylene or 100% post-consumer resin (non-regulated)
- Palletize with no overhang on a 40×48 pallet
- Meets FDA requirements for food contact, BPA free and Kosher
- Fluorination is available
- A variety of colors are available to choose (additional costs may apply)
- Reconditionable and recyclable

Specifications

Material	HDPE
Nominal Volume	20L / 5 Gal
Overflow Volume	21.3 L / 5.6 Gal
Neck Finish	76TE (6 TPI)
Vent	22mm Closed Vent
Bottle Dimensions (L x W x H)	11" x 10 5/8" x 14 3/8"
UN	Regulated
FDA	Resin meets FDA standards

Shipping Information

Bundle (quantity/pallet)	112 (48/64)
53' Truckload Capacity	3,136
Pallet Dimensions	40 x 48

DISTRIBUTED BY:



REF NO.:

DWGxxxxx

DISCLAIMER

THIS INFORMATION IS PROVIDED AS A GENERAL GUIDE, INCLUDING DIMENSIONS. IT IS THE CUSTOMER'S RESPONSIBILITIES TO SELECT THE PROPER CONTAINER FOR PRODUCT AND APPLICATION COMPATIBILITY.

DESCRIPTION:
20 Liter Blue HDPE Plastic Rectangular Tight Head,
70 mm